



**RAILCAR PROTECTION FROM A END TO B END**

The PowRGuard™ draft gears from A. Stucki Company are designed to be a high quality, durable solution for railcar owners and operators. The Group J model, the PowRGuard XE, is an all-metal gear with excellent wear characteristics. With an official rating capacity of 47,054 ft-lbs, the PowRGuard XE exceeds capacity of other gears in its class, with added benefits of excellent wear characteristics. Our simple formula equals outstanding protection against a car's lading over time and is fully-approved by the AAR under M-901E.

As a full-line supplier, we also offer draft gear reconditioning services regardless of OEM. We understand our customers' needs and develop the right solutions to their railcar challenges today, tomorrow, and in the future. At A.Stucki Company, we are no longer providing only freight/rail products and services, we deliver turnkey solutions.



**Features**

- Special heat treating processes which improve wear characteristics
- Movable plates provide additional friction surfaces and energy damping
- Visual wear indicators are easy to use
- No physical gaging is necessary when gear is installed (and difficult to reach) under car body
- Excellent end-of-car protection for longer life
- Proven track record in the field

**PowRGuard™**

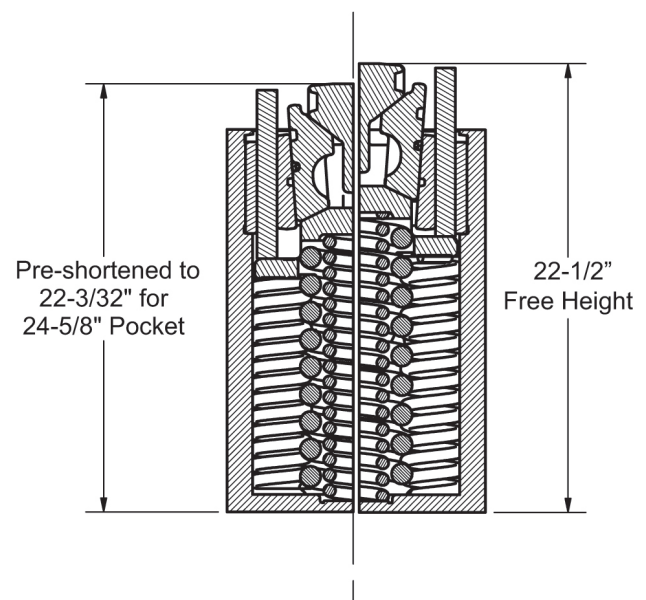

For Australian Distribution Contact Sigra Technology Australia Pty Ltd



[www.sigrail.com](http://www.sigrail.com)



(02) 4732 144

@ [sales@sigrail.com](mailto:sales@sigrail.com)

**Technical Specifications:**

	PowRGuard XE	PowRGuard GXE	PowRGuard GX
Standard Pocket	Fits 24-5/8"	Fits 24-5/8"	Fits 24-5/8"
AAR Approval	M-901E	M-901E	M-901G
Official Rating Capacity	47,054 ft-lbs	45,643 ft-lbs	N/A
Approximate Weight	364 lbs	367 lbs	365 lbs
Group	Group J	Group J	Group K
Travel	3-1/4"	3-1/4"	3-1/4"
Maximum Rating Impact Velocity	N/A	N/A	5.9 mph
Full Warranty	Yes	Yes	Yes
arrives pre-shortened	Yes	Yes	Yes
Fits all standard yoke & car construction	Yes	Yes	Yes
	All steel	All steel with elastomer insert	All steel with elastomer insert

**PowRGuard™ XE, GXE, GX**



**Stucki Wear Tab Difference:**

- PowRGuard Draft Gear (all-metal, Group J)
- Simple visual wear indicator
- No measurement or inspection gages necessary
- Gear is worn when the movable plate contacts the wear tab

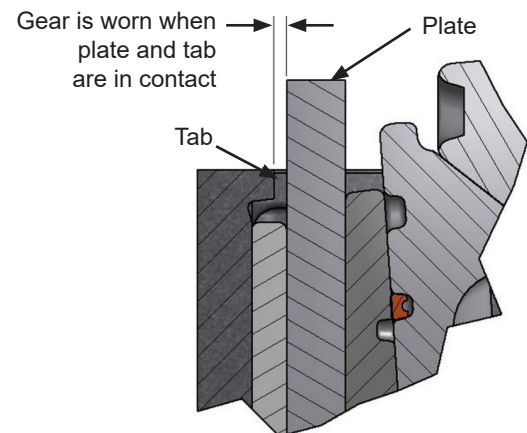
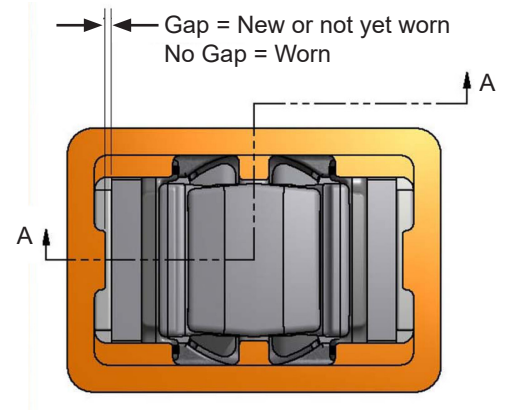

For Australian Distribution Contact Sibra Technology Australia Pty Ltd



www.sigrail.com



(02) 4732 1433

@ sales@sigrail.com